

The Effect of LNA Metal Boxes upon S11 and Angle (Theta) of Peak Gain Along Excitation Axis

Update

Tom Mozdzen

9/12/2013

Two new top plate capacitor geometries were investigated to determine their effect upon the beam pattern symmetry. The reference top plate is shown in figure 1, and the two alternate designs are shown in figures 2 and 3. Figure 4 shows the S11 patterns and Figure 5 shows the maximum gain angle of theta along the phi=0 direction (excitation axis).

The symmetrical design (Fig. 3) lowers the beam tilt angle, but the S11 curve degrades by ~3 dB. Further tuning is needed to remove this degradation. The design with a narrow lead going to the main plate capacitor (Fig. 2) shows promise in S11 but requires a little bit of tuning to be equivalent to the reference case. Beam tilt angles were not available at the moment in that CST fatally exited at the end of the run and CST support is working on resolving the cause of the crash.

The reference plate capacitor gives a solid S11 result with known beam peak tilt issues and should be our default geometry. Further work will be done to reconfirm the results without CST crashes and versions of the plate capacitor will be manufactured for experimental S11 measurements.

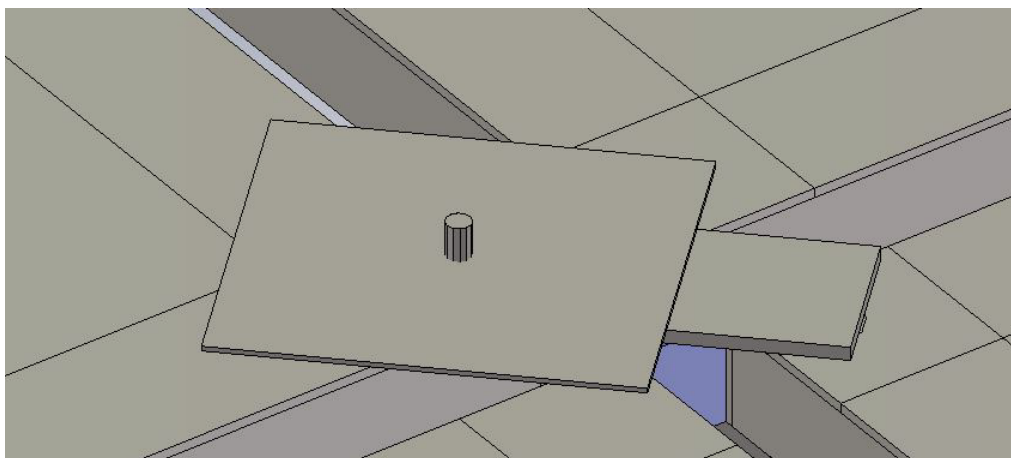

Figure 1. Reference top plate capacitor.

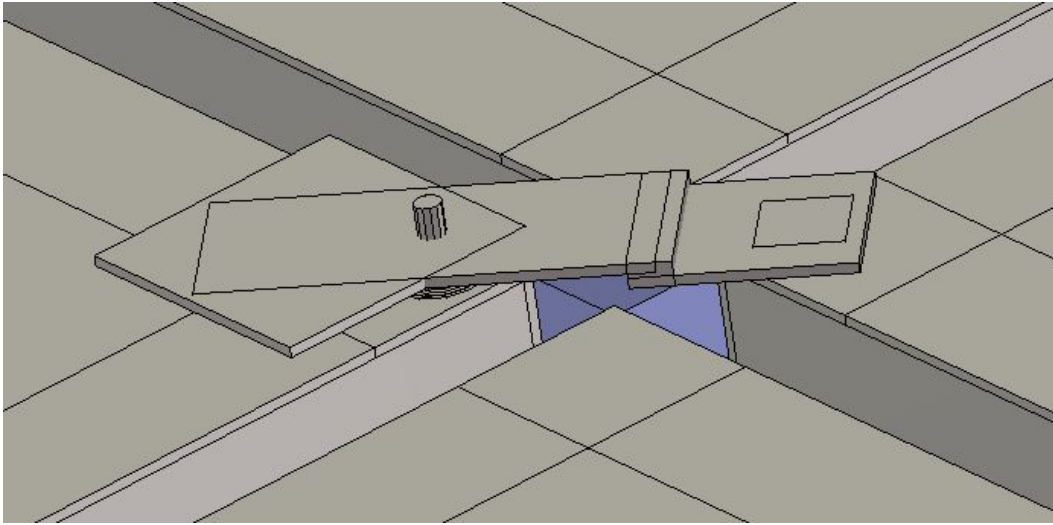

Figure 2. Alternate design 1.

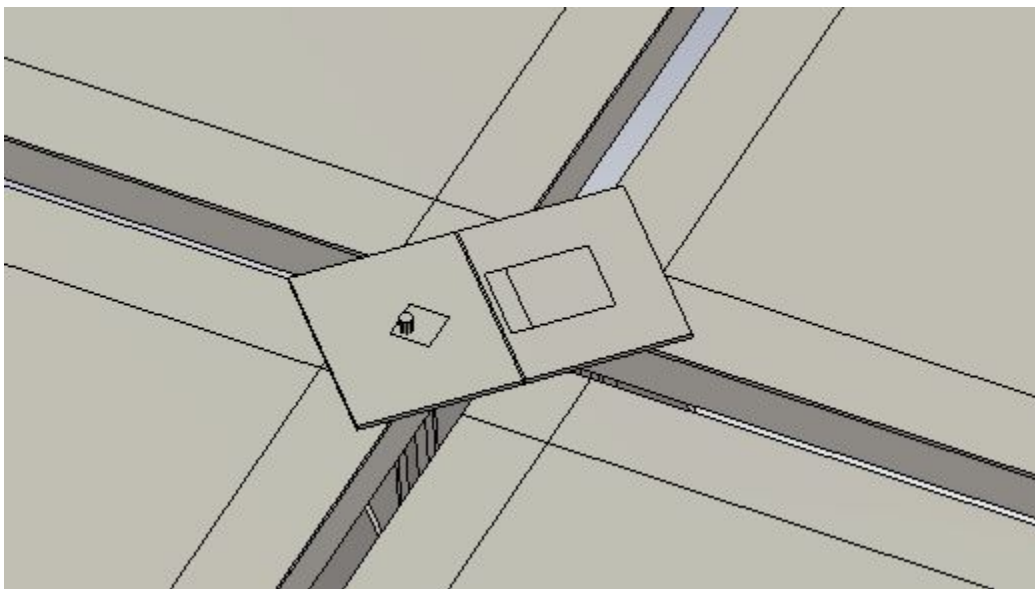

Figure 3. Alternate design 2.

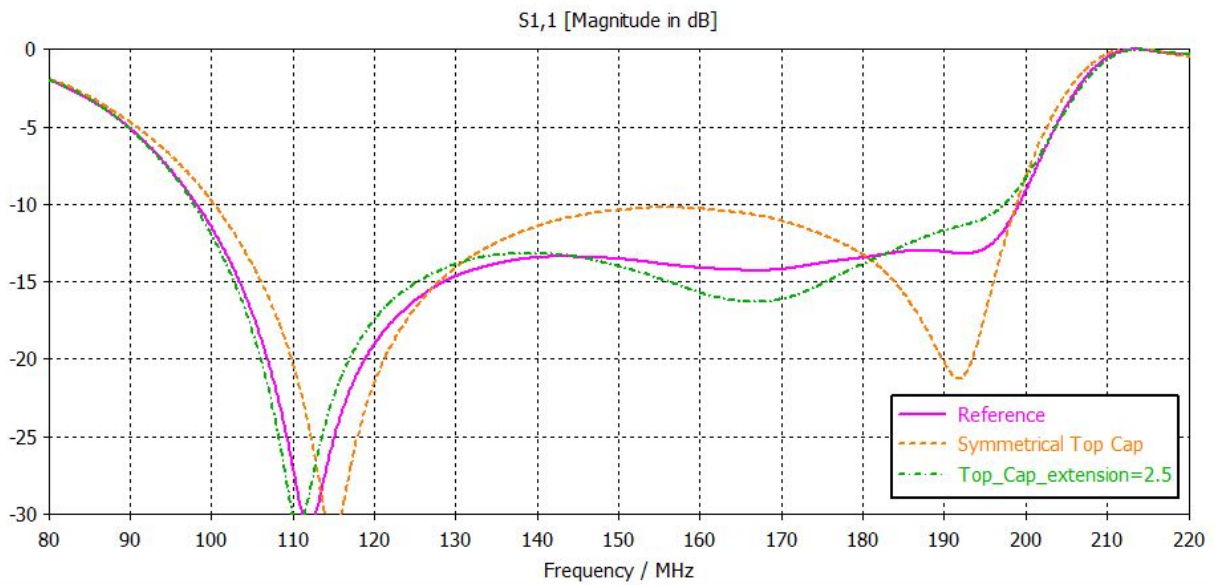

Figure 4. S11 responses of the various top cap geometries.

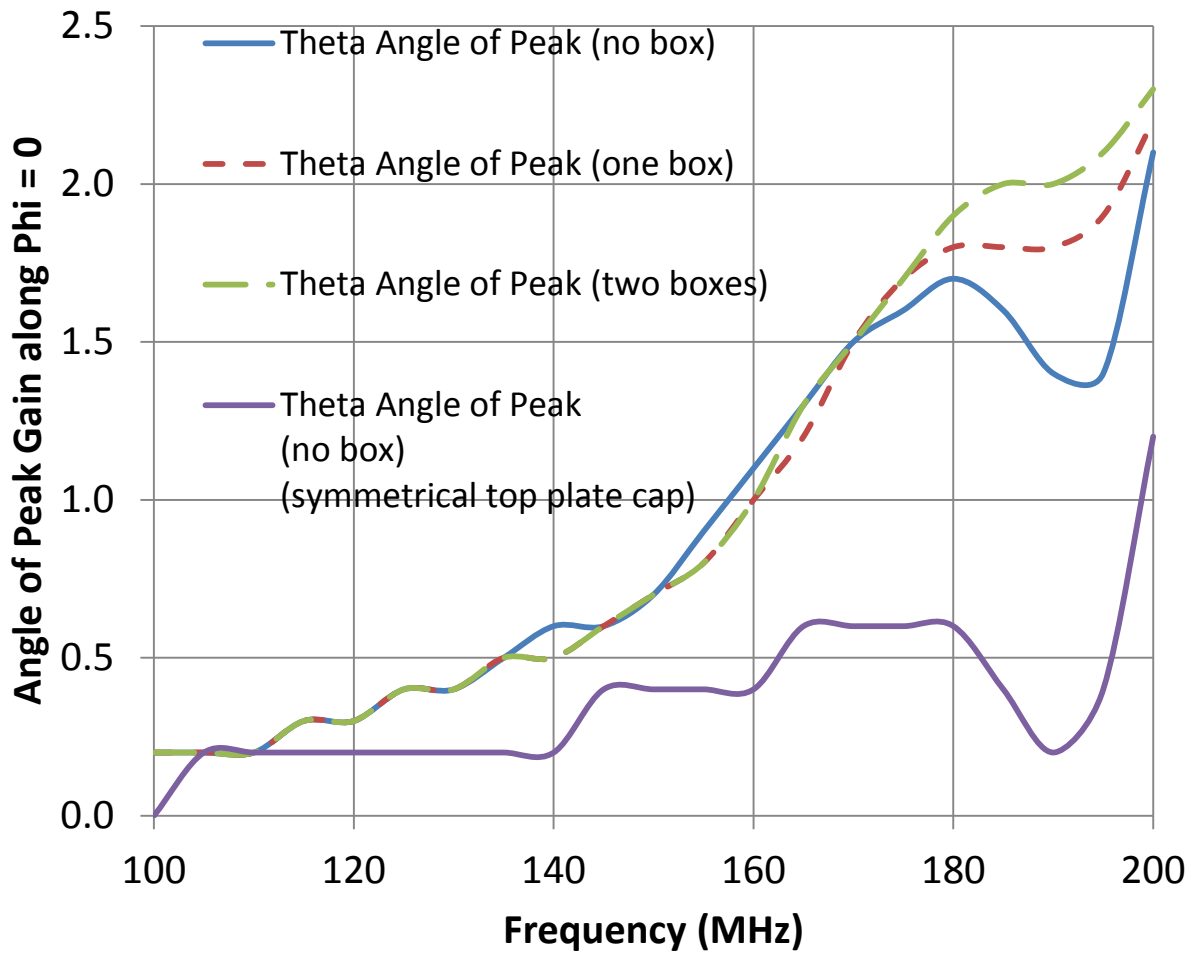

Figure 5. Graph of the peak gain angle vs Frequency.